

FORM TWO MATHEMATICS **TOPICAL QUESTIONS**



AMOBI SOFT COPY PUBLISHERS

Transparency, Honesty and Accountability Defined

F2 MATHS TOPICAL QUESTIONS

**Prefer Calling Sir Obiero Amos @
0706 851 439
for the Marking Schemes**

N/B Marking Schemes are **NOT** Free of Charge

ONLY Questions Are Free of Charge

ACTED SET BOOKS VIDEOS.

Details Inscribed in each. Delivered Via Telegram.

WhatsApp/Sms/Call Sir Obiero Amos

0706 851 439



TOPIC 1

NUMBERS

1. Use logarithms to evaluate

$$\frac{3 \sqrt[3]{36.15 \times 0.02573}}{1,938}$$

2. Find the value of x which satisfies the equation.

$$16^{x^2} = 8^{4x-3}$$

3. Use logarithms to evaluate $\frac{(1934)^2 \times \sqrt{0.00324}}{436}$

4. Use logarithms to evaluate

$$55.9 \div (02621 \times 0.01177)^{1/5}$$

5. Simplify $2^x \times 5^{2x} \div 2^{-x}$

6. Use logarithms to evaluate

$$(3.256 \times 0.0536)^{1/3}$$

7. Solve for x in the equation

$$32^{(x-3)} \div 8^{(x-4)} = 64 \div 2^x$$

8. Solve for x in the equations $\frac{81^{2x} \times 27^x}{9^x} = 729$

9. Use reciprocal and square tables to evaluate to 4 significant figures, the expression:

$$\frac{1}{24.56} + 4 \cdot 346^2$$

10. Use logarithm tables, to evaluate

$$\frac{0.032 \times 14.26}{0.006}^{2/3}$$

11. Find the value of x in the following equation

$$49^{(x+1)} + 7^{(2x)} = 350$$

12. Use logarithms to evaluate

$$\frac{(0.07284)^2}{3\sqrt{0.06195}}$$

13. Find the value of m in the following equation

$$(1/27^m \times (81)^{-1}) = 243$$

14. Given that $P = 3^y$ express the equation $3^{(2y-1)} + 2 \times 3^{(y-1)} = 1$ in terms of P hence or otherwise find the value of y in the equation $3^{(2y-1)} + 2 \times 3^{(y-1)} = 1$

15. Use logarithms to evaluate $55.9 \div (0.2621 \times 0.01177)^{1/5}$

16. Use logarithms to evaluate

$$\frac{6.79 \times 0.3911}{\text{Log } 5}^{3/4}$$

17. Use logarithms to evaluate

$$\frac{3 \times 1.23 \times 0.0089}{79.54}$$

18. Solve for x in the equation

$$X = \frac{0.0056}{1.38 \times 27.42}^{1/2}$$

TOPIC 2: EQUATIONS OF LINES

1. The coordinates of the points P and Q are (1, -2) and (4, 10) respectively.

A point T divides the line PQ in the ratio 2: 1

(a) Determine the coordinates of T

(b) (i) Find the gradient of a line perpendicular to PQ

(ii) Hence determine the equation of the line perpendicular PQ and passing through T

(iii) If the line meets the y- axis at R, calculate the distance TR, to three significant figures

2. A line L_1 passes through point (1, 2) and has a gradient of 5. Another line L_2 , is perpendicular to L_1 and meets it at a point where $x = 4$. Find the equation for L_2 in the form of $y = mx + c$

3. P (5, -4) and Q (-1, 2) are points on a straight line. Find the equation of the perpendicular bisector of PQ: giving the answer in the form $y = mx + c$.

4. On the diagram below, the line whose equation is $7y - 3x + 30 = 0$ passes through the points A and B. Point A on the x-axis while point B is equidistant from x and y axes.

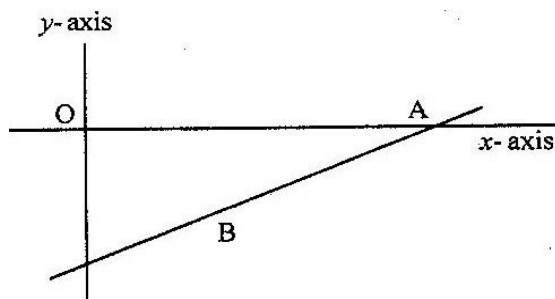

Calculate the co-ordinates of the points A and B

5. A line with gradient of -3 passes through the points $(3, k)$ and $(k, 8)$. Find the value of k and hence express the equation of the line in the form $ax + by = c$, where a , b , and c are constants.
6. Find the equation of a straight line which is equidistant from the points $(2, 3)$ and $(6, 1)$, expressing it in the form $ax + by = c$ where a , b and c are constants.
7. The equation of a line $-\frac{3}{5}x + 3y = 6$. Find the:
 - (a) Gradient of the line (1 mk)
 - (b) Equation of a line passing through point $(1, 2)$ and perpendicular to the given line
8. Find the equation of the perpendicular to the line $x + 2y = 4$ and passes through point $(2, 1)$
9. Find the equation of the line which passes through the points $P(3, 7)$ and $Q(6, 1)$
10. Find the equation of the line whose x - intercept is -2 and y - intercept is 5
11. Find the gradient and y - intercept of the line whose equation is $4x - 3y - 9 = 0$

TOPIC 3

TRANSFORMATIONS

1. A translation maps a point $(1, 2)$ onto $(-2, 2)$. What would be the coordinates of the object whose image is $(-3, -3)$ under the same translation?

2. Use binomial expression to evaluate $(0.96)^5$ correct to 4 significant figures

11. In the figure below triangle ABO represents a part of a school badge. The badge has as symmetry of order 4 about O. Complete the figures to show the badge.

3. A point $(-5, 4)$ is mapped onto $(-1, -1)$ by a translation. Find the image of $(-4, 5)$ under the same translation.

4. A triangle is formed by the coordinates A $(2, 1)$ B $(4, 1)$ and C $(1, 6)$. It is rotated clockwise through 90° about the origin. Find the coordinates of this image.

5. The diagram on the grid provided below shows a trapezium ABCD

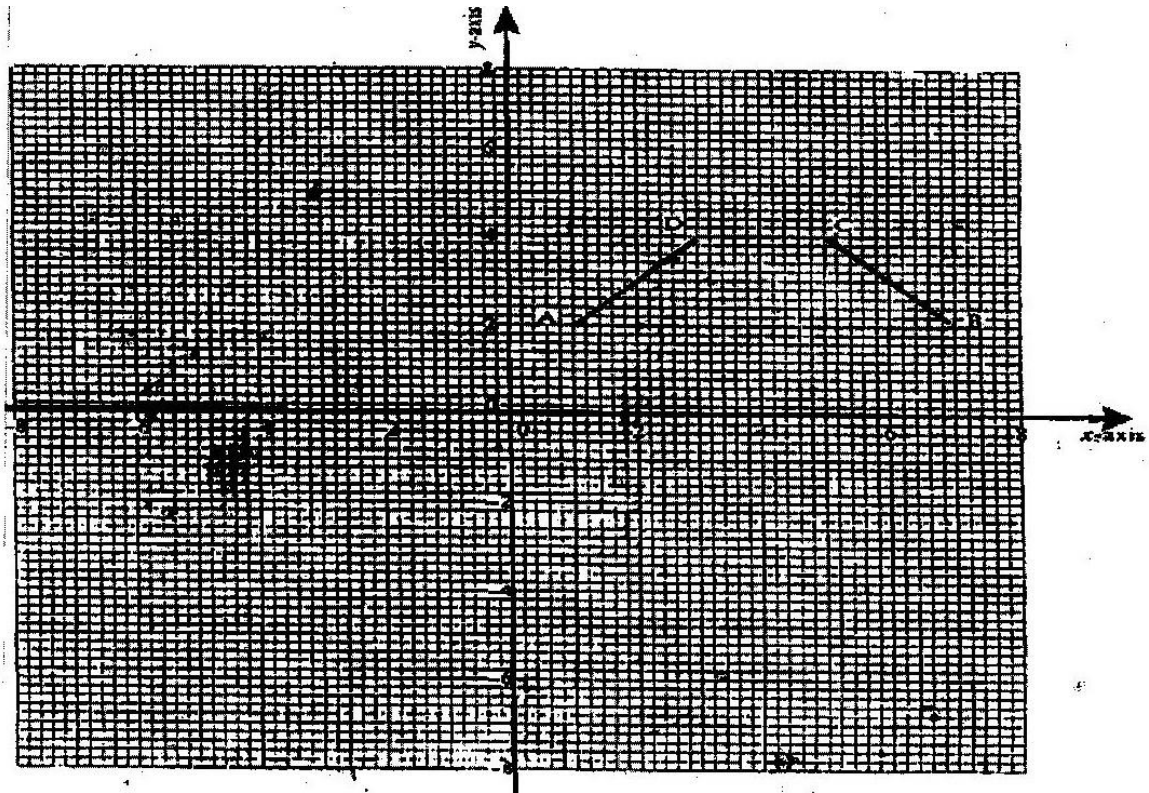

On the same grid

(a) (i) Draw the image $A'B'C'D'$ of ABCD under a rotation of 90° clockwise about the origin .

(ii) Draw the image of $A''B''C''D''$ of $A'B'C'D'$ under a reflection in line $y = x$. State coordinates of $A''B''C''D''$.

(b) $A''B''C''D''$ is the image of $A''B''C''D''$ under the reflection in the line $x=0$.

Draw the image $A''B''C''D''$ and state its coordinates.

(c) Describe a single transformation that maps $A''B''C''D''$ onto ABCD.

6. A translation maps a point P (3,2) onto P'(5,4)
- (a) Determine the translation vector
- (b) A point Q' is the image of the point Q (, 5) under the same translation. Find the length of 'P' Q leaving the answer is surd form.

7. Two points P and Q have coordinates (-2, 3) and (1, 3) respectively. A translation map point P to P' (10, 10)

- (a) Find the coordinates of Q' the image of Q under the translation(1 mk)
- (b) The position vector of P and Q in (a) above are p and q respectively given that $mp - nq = -129$

Find the value of m and n (3mks)

8. on the Cartesian plane below, triangle PQR has vertices P(2, 3), Q (1,2) and R (4,1) while triangles P'' q '' R'' has vertices P'' (-2, 3), Q'' (-1,2) and R'' (-4, 1)

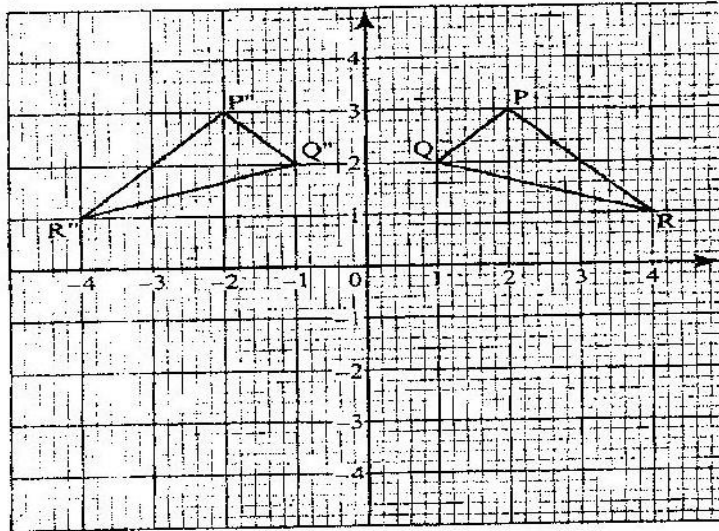

- (a) Describe fully a single transformation which maps triangle PQR onto triangle P''Q''R''
- (b) On the same plane, draw triangle P'Q'R', the image of triangle PQR, under reflection in line $y = -x$

- (c) Describe fully a single transformation which maps triangle $P'Q'R'$ onto triangle $P''Q''R''$
- (d) Draw triangle $P''Q''R''$ such that it can be mapped onto triangle PQR by a positive quarter turn about $(0, 0)$
- (e) State all pairs of triangle that are oppositely congruent

TOPIC 4:

MEASUREMENT

1. A solid cone of height 12 cm and radius 9 cm is recast into a solid sphere. Calculate the surface area of the sphere.

2. A circular path of width 14 metres surrounds a field of diameter 70 metres. The path is to be carpeted and the field is to have a concrete slab with an exception of four rectangular holes each measuring 4 metres by 3 metres.

A contractor estimated the cost of carpeting the path at Kshs. 300 per square metre and the cost of putting the concrete slab at Kshs 400 per square metre. He then made a quotation which was 15% more than the total estimate. After completing the job, he realized that 20% of the quotation was not spent.

- (a) How much money was not spent?
- (b) What was the actual cost of the contract?

3. In the figure below BAD and CBD are right angled triangles.

Find the length of AB.

4. A cylinder of radius 14 cm contains water. A metal solid cone of base radius 7 cm and height 18 cm is submerged into the water. Find the change in height of the water level in the cylinder.

5. A cylindrical container of radius 15 cm has some water in it. When a solid is submerged into the water, the water level rises by 1.2 cm.

(a) Find, the volume of the water displaced by the solid leaving your answer in terms of π

(b) If the solid is a circular cone of height 9 cm, calculate the radius of the cone to 2 decimal places.

6. A balloon, in the form of a sphere of radius 2 cm, is blown up so that the volume increases by 237.5%. Determine the new volume of balloon in terms of π

A girl wanted to make a rectangular octagon of side 14 cm. She made it from a square piece of a card of size y cm by cutting off four isosceles triangles whose equal sides were x cm each, as shown below.

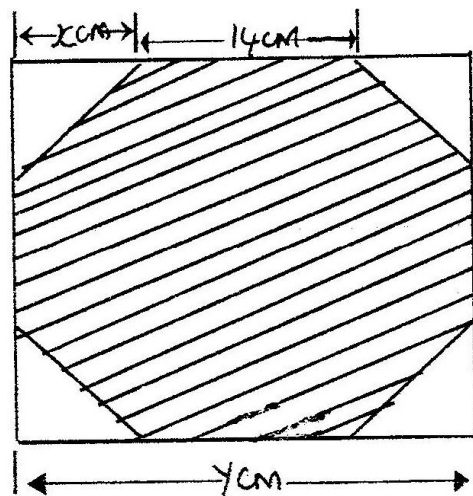

(a) Write down an expression for the octagon in terms of x and y

(b) Find the value of x

(c) Find the area of the octagon

7. A pyramid $VABCD$ has a rectangular horizontal base $ABCD$ with $AB = 12$ cm and $BC = 9$ cm. The vertex V is vertically above A and $VA = 6$ cm. Calculate the volume of the pyramid.
8. A solid made up of a conical frustrum and a hemisphere top as shown in the figure below. The dimensions are as indicated in the figure.

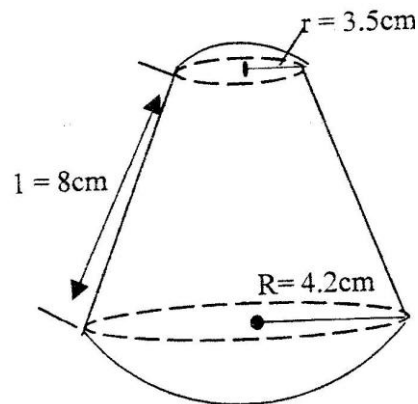

- (a) Find the area of
- The circular base
 - The curved surface of the frustrum
 - The hemisphere surface
- (b) A similar solid has a total area of 81.51 cm². Determine the radius of its base.
9. Two sides of triangles are 5 cm each and the angle between them is 120° . Calculate the area of the triangle.
10. The figure below represents a kite $ABCD$, $AB = AD = 15$ cm. The diagonals BD and AC intersect at O . $AC = 30$ cm and $AO = 12$ cm.

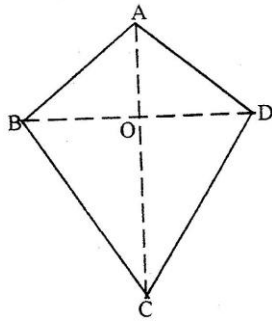

Find the area of the kite

11. The diagram below represents a solid made up of a hemisphere mounted on a cone. The radius of the hemisphere are each 6 cm and the height of the cone is 9 cm.

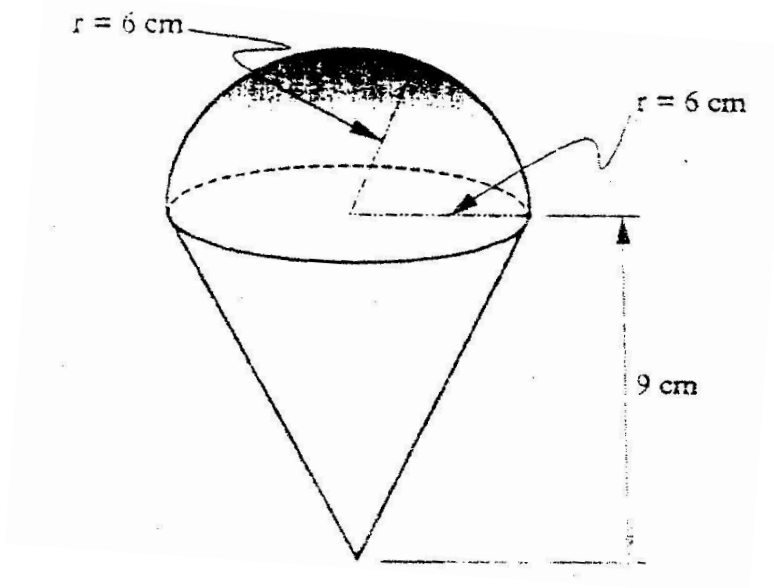

Calculate the volume of the solid take $\pi = \left(\frac{22}{7}\right)$

12. The internal and external diameters of a circular ring are 6 cm and 8 cm respectively. Find the volume of the ring if its thickness is 2 millimeters.

13. A wire of length 21 cm is bent to form the shape down in the figure below, ABCD is a rectangle and AEB is an equilateral triangle.

(2mks)

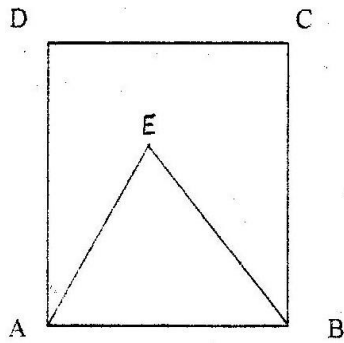

If the length of AD of the rectangle is $1\frac{1}{2}$ times its width, calculate the width of the rectangle.

14. The length of a hollow cylindrical pipe is 6 metres. Its external diameter is 11 cm and has a thickness of 1 cm. Calculate the volume in cm^3 of the material used to make the pipe. Take π as 3.142

15. The figure below represents a hexagonal prism of side 5 cm and 20 cm height

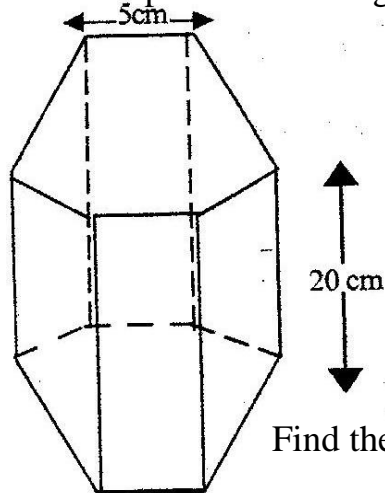

Find the volume of the prism.

16. A cylindrical piece of wood of radius 4.2 cm and length 150 cm is cut length into two equal pieces.

Calculate the surface area of one piece (Take π as $\frac{22}{7}$)

17. The figure below is a model representing a storage container. The model whose total height is 15 cm is made up of a conical top, a hemispherical

bottom and the middle part is cylindrical. The radius of the base of the cone and that of the hemisphere are each 3 cm. The height of the cylindrical part is 8 cm.

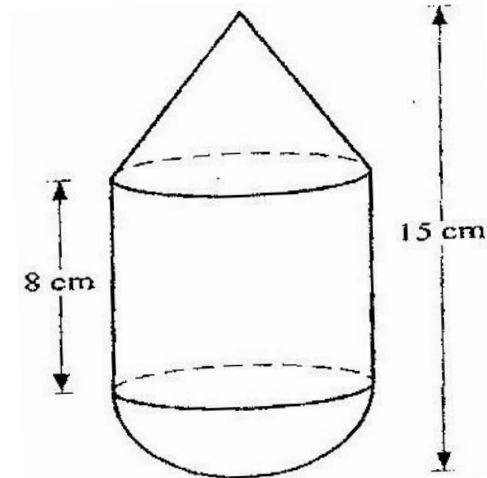

- (a) Calculate the external surface area of the model
- (b) The actual storage container has a total height of 6 metres. The outside of the actual storage container is to be painted. Calculate the amount of paint required if an area of 20m^2 requires 0.75 litres of the paint.

18. A garden measures 10m long and 8 m wide. A path of uniform width is made all round the garden. The total area of the garden and the paths is 168 m^2 .

- (a) Find the width of the path
- (b) The path is to be covered with square concrete slabs. Each corner of the path is covered with a slab whose side is equal to the width of the path.

The rest of the path is covered with slabs of side 50 cm. The cost of making each corner slab is Kshs 600 while the cost of making each smaller slab is Kshs 50.

Calculate

- (i) The number of smaller slabs used
- (ii) The total cost of the slabs used to cover the whole path

19. A cylindrical solid of radius 5 cm and length 12 cm floats lengthwise in water to a depth of 2.5 cm as shown in the figure below.

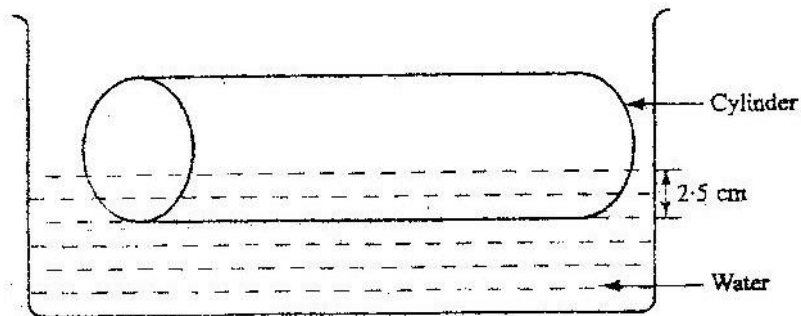

Calculate the area of the curved surface of the solid in contact with water, correct to 4 significant figures

20. Two cylindrical containers are similar. The larger one has internal cross-section area of 45 cm^2 and can hold 0.945 litres of liquid when full. The smaller container has internal cross-section area of 20 cm^2

- (a) Calculate the capacity of the smaller container
- (b) The larger container is filled with juice to a height of 13 cm. Juice is then drawn from it and emptied into the smaller container until the depths of the juice in both containers are equal. Calculate the depths of juice in each container.

(c) On fifth of the juice in the larger container in part (b) above is further drawn and emptied into the smaller container. Find the difference in the depths of the juice in the two containers.

22. A metal bar is a hexagonal prism whose length is 30 cm, the cross section is a regular hexagon with each side of length 6 cm
- Find
- (i) The area of the hexagonal face (3mks)
 - (ii) The volume of the metal bar (2mks)
23. A cylindrical water tank of diameter 7 metres and height 2.8 metres
- (a) Find the capacity of the water tank in litres
 - (b) Six members of family use 15 litres each per day. Each day 80 litres are used for cooking and washing and a further 60 litres are wasted. Find the number of complete days a full tank would last the family (2mks)
 - (c) Two members of the family were absent for 90 days. During the 90 days wastage was reduced by 20% but cooking and washing remained the same. Calculate the number of days a full tank would now last the family
24. Pieces of soap are packed in a cuboid container measuring 36 cm by 24 cm by 18 cm. Each piece of soap is similar to the container. If the linear scale factor between the container and the soap is $\frac{1}{6}$ find the volume of each piece of soap.
25. A pyramid of height 10cm stands, on a square base ABCD of side 6 cm.
- (a) Draw a sketch of the pyramid
 - (b) Calculate the perpendicular distance from the vertex to the side AB.

TOPIC 5

QUADRATIC EQUATIONS

1. Simplify

$$\frac{2x - 2}{6x^2 - x - 12} \div \frac{x - 1}{2x - 3}$$

2. Solve the simultaneous equations

$$2x - y = 3$$

$$x^2 - xy = -4$$

3. Find the value of x in the following equations:

$$49^{x+1} + 7^{2x} = 350$$

4. Simplify completely

$$\frac{3x^2 - 1 - 2x + 1}{x^2 - 1} \cdot \frac{1}{x + 1}$$

5. Factorize completely $3x^2 - 2xy - y^2$

6. Factorize $a^2 - b^2$

Hence find the exact value of $2557^2 - 2547^2$

7. If $x^2 + y^2 = 29$ and $x + y = 3$

(a) Determine the values of

(i) $x^2 + 2xy + y^2$

- (ii) $2xy$
- (iii) $x^2 - 2xy + y^2$
- (iv) $x - y$

(b) Find the value of x and y

8. Simplify the expression $\frac{3a^2 + 4ab + b^2}{4a^2 + 3ab - b^2}$

9. (a) Write an expression in terms of x and y for the total value of a two digit number having x as the tens digit and y as the units digit.

b) The number in (a) above is such that three times the sum of its digits is less than the value of the number by 8. When the digits are reversed the value of the number increases by 9. Find the number xy.

10. Simplify the expression $\frac{2a^2 - 3ab - 2b^2}{4a^2 - b^2}$

11. Simplify the expression $\frac{9t^2 - 25a^2}{6t^2 + 19at + 15a^2}$

12. Simplify

$$\frac{p^2 + 2pq + q^2}{p^3 - pq^2 + p^2q - q^3}$$

13. Expand the expression $(x^2 - y^2)(x^2 + y^2)(x^4 - y^4)$

14. The sum of two numbers x and y is 40. Write down an expression, in terms of x , for the sum of the squares of the two numbers.

Hence determine the minimum value of $x^2 + y^2$

15. Simplify the expression $\frac{15a^2b - 10ab^2}{-5ab + 2b^2}$

16. Four farmers took their goats to the market. Mohamed had two more goats than Ali Koech had 3 times as many goats as Mohamed. Whereas Odupoy had 10 goats less than both Mohamed and Koech.

(i) Write a simplified algebraic expression with one variable.

Representing the total number of goats

(ii) Three butchers bought all the goats and shared them equally. If each butcher got 17 goats. How many did Odupoy sell to the butchers?

17. Find the value of x which satisfies the equation $16^{2x} = 8^{4x-3}$

18. Mary has 21 coins whose total value is Kshs 72. There are twice as many five shillings coins as there are ten shillings coins. The rest one shilling coins. Find the number of ten shilling coins that Mary has.

19. Simplify the expression

$$\frac{x-1}{x} - \frac{2x+1}{3x}$$

Hence solve the equation $\frac{x-1}{x} - \frac{2x+1}{3x} = 2$

$$x \quad 3x \quad 3$$

20. Given that $P = 3^y$ express the equation

$$3^{2y-1} + 2 \times 3^{y-1} = 1 \text{ in terms of } P.$$

Hence or otherwise find the value of y in the equation $3^{2y-1} + 2 \times 3^{y-1} = 1$

21. Simplify the expression

$$\frac{4x^2 - y^2}{2x^2 - 7xy + 3y}$$

22. Three years ago Juma was three times as old as Ali. In two years time the sum of their ages will be 62. Determine their present ages.

23. Simplify

$$\frac{x-2}{x+2} - \frac{2x+20}{x^2-4}$$

24. If the expression $25y^2 - 70y + d$ is a perfect square, where d is a constant, find the value of d

TOPIC 6

INEQUALITIES

1. Find the range of x if $2 \leq 3 - x < 5$

2. Find all the integral values of x which satisfy the inequalities:
 $2(2-x) < 4x - 9 < x + 11$

3. Solve the inequality and show the solution
 $3 - 2x < x \leq \frac{2x + 5}{3}$ on the number line

4. Solve the inequality $\frac{x - 3}{4} + \frac{x - 5}{6} \leq \frac{4x + 6}{8} - 1$

5. A family is planning a touring holiday, during which time (x days) will be spent walking and the rest of the time (y days) in traveling by bus. Each day they can walk 30 km or travel 80 km by bus and they wish to travel at least 600 km altogether.
The holiday must not last more than 14 days. Each day walking will cost Kshs. 200 and each day traveling by bus will cost Kshs. 1400.
The holiday must not cost more than Kshs 9800
 - (a) Write down all the inequalities in x and y based on the above facts
 - (b) Represent the inequalities graphically
 - (c) Use the graph to determine the integral values of x and y which give
 - (i) The cheapest holiday
 - (ii) The longest distance traveled

TOPIC 7 CIRCLES

1. In the figure below $CP = CQ$ and $\angle CQP = 160^\circ$. If $ABCD$ is a cyclic quadrilateral, find $\angle BAD$.

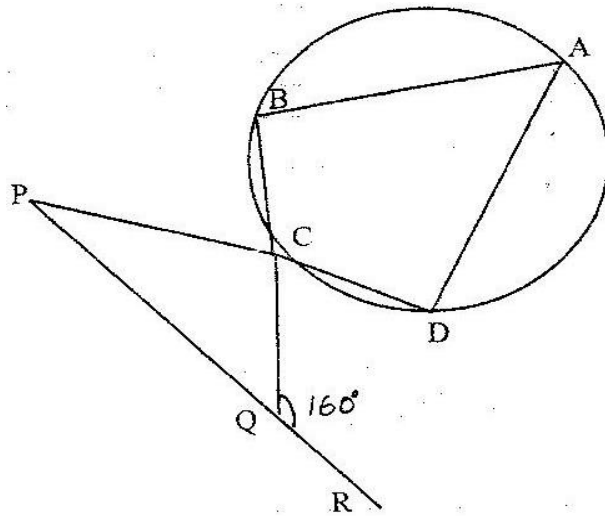

2. In the figure below AOC is a diameter of the circle centre O ; $AB = BC$ and $\angle ACD = 25^\circ$, EBF is a tangent to the circle at B . G is a point on the minor arc CD .

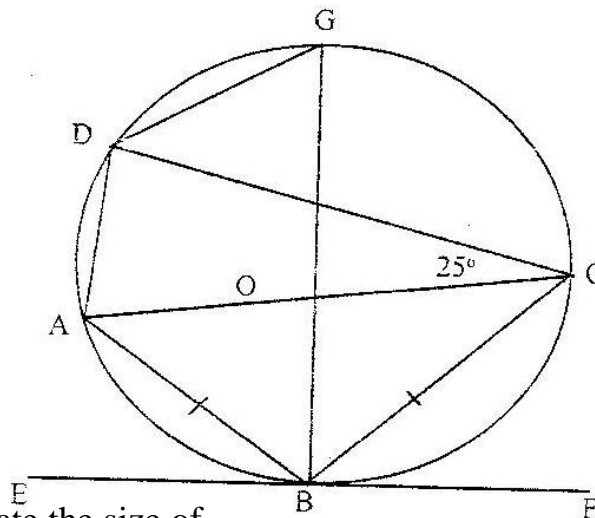

- (a) Calculate the size of

(i) $\angle BAD$

(ii) The Obtuse $\angle BOD$

(iii) $\angle BGD$

(b) Show the $\angle ABE = \angle CBF$. Give reasons

3. In the figure below PQR is the tangent to circle at Q. TS is a diameter and TSR and QUV are straight lines. QS is parallel to TV. Angles $\angle SQR = 40^\circ$ and $\angle TQV = 55^\circ$

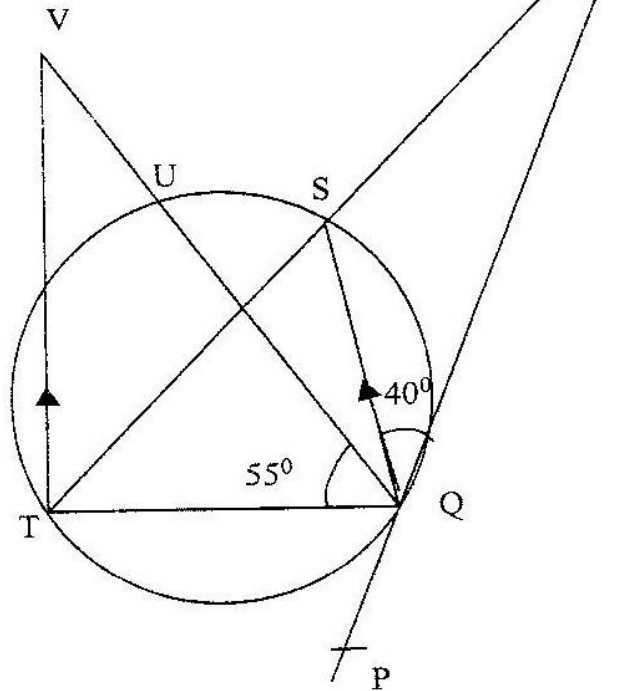

Find the following angles, giving reasons for each answer

- (a) $\angle QST$
- (b) $\angle QRS$
- (c) $\angle QVT$
- (d) $\angle UTV$

4. In the figure below, QOT is a diameter. $\angle QTR = 48^\circ$, $\angle TQR = 76^\circ$ and $\angle SRT = 37^\circ$

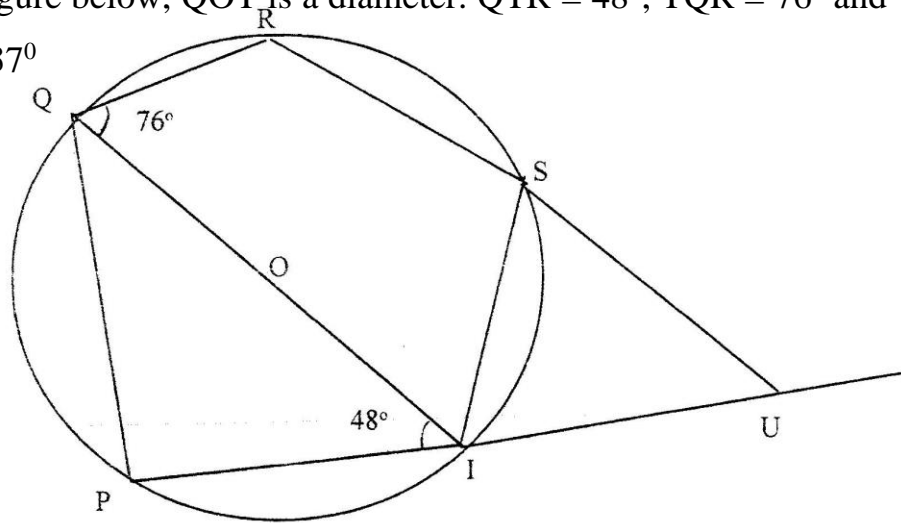

Calculate

- $\angle RST$
 - $\angle SUT$
 - Obtuse $\angle ROT$
5. In the figure below, points O and P are centers of intersecting circles ABD and BCD respectively. Line ABE is a tangent to circle BCD at B . Angle $BCD = 42^\circ$

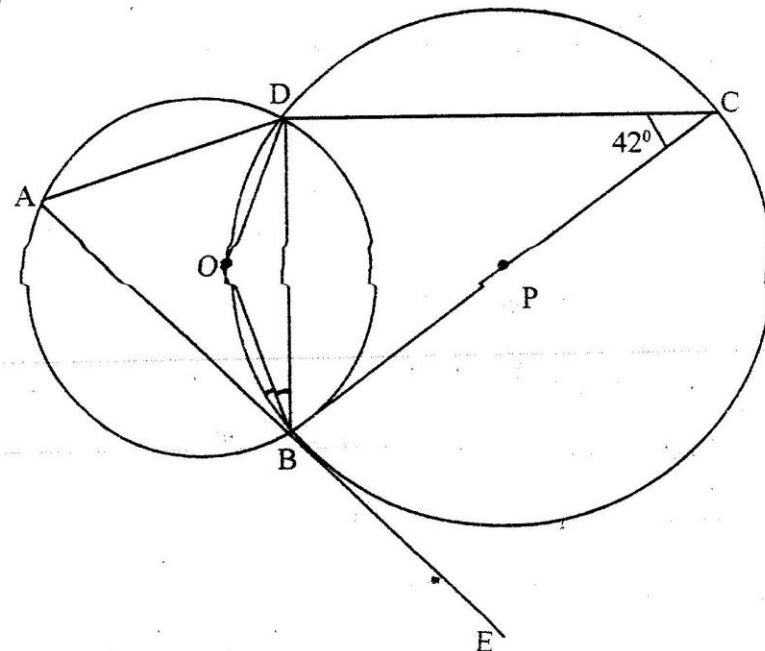

(a) Stating reasons, determine the size of

(i) $\angle CBD$

(ii) Reflex $\angle BOD$

(b) Show that $\triangle ABD$ is isosceles

6. The diagram below shows a circle $ABCDE$. The line FEG is a tangent to the circle at point E . Line DE is parallel to CG , $\angle DEC = 28^\circ$ and $\angle AGE = 32^\circ$

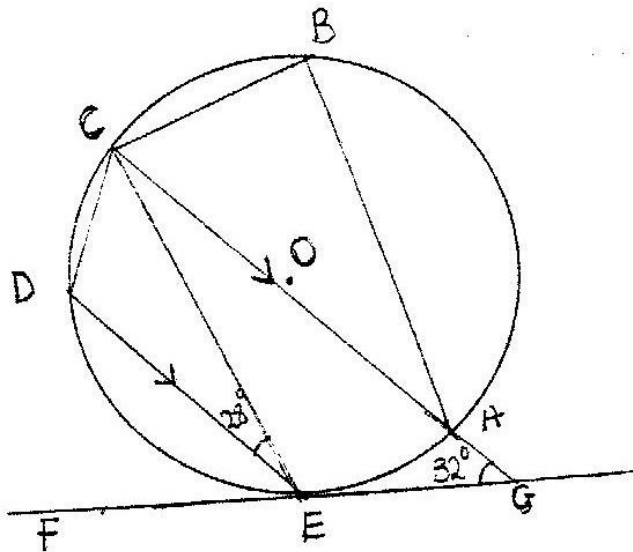

Calculate:

(a) $\angle AEG$

(b) $\angle ABC$

7. In the figure below R , T and S are points on a circle centre O . PQ is a tangent to the circle at T . POR is a straight line and $\angle QPR = 20^\circ$

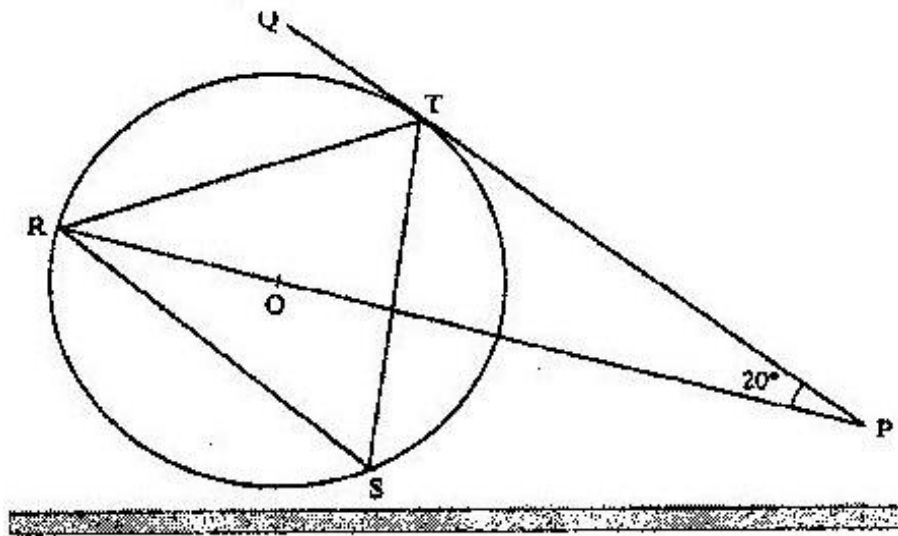

Find the size of $\angle RST$

TOPIC 8

LINEAR MOTION

1. Two towns P and Q are 400 km apart. A bus left P for Q. It stopped at Q for one hour and then started the return journey to P. One hour after the departure of the bus from P, a trailer also heading for Q left P. The trailer met the returning bus $\frac{3}{4}$ of the way from P to Q. They met t hours after the departure of the bus from P.
 - (a) Express the average speed of the trailer in terms of t
 - (b) Find the ratio of the speed of the bus so that of the trailer.

2. The athletes in an 800 metres race take 104 seconds and 108 seconds respectively to complete the race. Assuming each athlete is running at a constant speed. Calculate the distance between them when the faster athlete is at the finishing line.

3. A and B are towns 360 km apart. An express bus departs from A at 8 am and maintains an average speed of 90 km/h between A and B. Another bus starts from B also at 8 am and moves towards A making four stops at four equally spaced points between B and A. Each stop is of duration 5 minutes and the average speed between any two spots is 60 km/h. Calculate distance between the two buses at 10 am.

4. Two towns A and B are 220 km apart. A bus left town A at 11. 00 am and traveled towards B at 60 km/h. At the same time, a matatu left town B for town A and traveled at 80 km/h. The matatu stopped for a total of 45 minutes on the way before meeting the bus. Calculate the distance covered by the bus before meeting the matatu.
5. A bus travels from Nairobi to Kakamega and back. The average speed from Nairobi to Kakamega is 80 km/hr while that from Kakamega to Nairobi is 50 km/hr, the fuel consumption is 0.35 litres per kilometer and at 80 km/h, the consumption is 0.3 litres per kilometer .Find
- Total fuel consumption for the round trip
 - Average fuel consumption per hour for the round trip.
6. The distance between towns M and N is 280 km. A car and a lorry travel from M to N. The average speed of the lorry is 20 km/h less than that of the car. The lorry takes 1h 10 min more than the car to travel from M and N.
- If the speed of the lorry is x km/h, find x (5mks)
 - The lorry left town M at 8: 15 a.m. The car left town M and overtook the lorry at 12.15 p.m. Calculate the time the car left town M.
7. A bus left Mombasa and traveled towards Nairobi at an average speed of 60 km/hr. after $2\frac{1}{2}$ hours; a car left Mombasa and traveled along the same road at an average speed of 100 km/ hr. If the distance between Mombasa and Nairobi is 500 km, Determine

- (a) (i) The distance of the bus from Nairobi when the car took off (2mks)
- (ii) The distance the car traveled to catch up with the bus
- (b) Immediately the car caught up with the bus
- (c) The car stopped for 25 minutes. Find the new average speed at which the car traveled in order to reach Nairobi at the same time as the bus.
8. A rally car traveled for 2 hours 40 minutes at an average speed of 120 km/h. The car consumes an average of 1 litre of fuel for every 4 kilometers.
A litre of the fuel costs Kshs 59
Calculate the amount of money spent on fuel
9. A passenger notices that she had forgotten her bag in a bus 12 minutes after the bus had left. To catch up with the bus she immediately took a taxi which traveled at 95 km/hr. The bus maintained an average speed of 75 km/ hr. determine
- (a) The distance covered by the bus in 12 minutes
- (b) The distance covered by the taxi to catch up with the bus
10. The athletes in an 800 metre race take 104 seconds and 108 seconds respectively to complete the race. Assuming each athlete is running at a constant speed. Calculate the distance between them when the faster athlete is at the finishing line.

11. Mwangi and Otieno live 40 km apart. Mwangi starts from his home at 7.30 am and cycles towards Otieno's house at 16 km/h. Otieno starts from his home at 8.00 and cycles at 8 km/h towards Mwangi. At what time do they meet?
12. A train moving at an average speed of 72 km/h takes 15 seconds to completely cross a bridge that is 80m long.
- (a) Express 72 km/h in metres per second
- (b) Find the length of the train in metres

PREFER CALLING SIR OBIERO AMOS @
0706 851 439
FOR QUICK SERVICE

**ACQUIRE THE FOLLOWING
KASNEB NOTES/REVISION KITS
NOW :**

CPA
ATD
CS

CICT
CIFA



AMOB! SOFT COPY PUBLISHERS
Transparency, Honesty and Accountability Defined

